

U/L
Listed

- ASME Code Constructed Boiler for 150 psi Steam Working Pressure.
- Three Pass Design features a rear combustion chamber that's totally submerged within the boiler water. This eliminates the need for refractory baffles, reduces costly maintenance, eliminating refractory replacement. Heat loss is minimized and overheating of the rear tube sheet is prevented. The wetback surface becomes additional primary heating surface, improving boiler performance.
- All Heating surfaces are accessible without disturbing burner equipment, reducing inspection and maintenance costs. Separate rear tube sheets eliminate warpage that would result from heat differentials between passes. All tubes are roller expanded. 2" Boiler tubes are used on 80-250 hp and 2½" tubes 300-750 hp.
- Factory installed 22 gauge enameled steel jacket with mineral fiber insulation. Extra density insulation is used at selected locations for additional protection at potential pressure points.
- Hinged steel front flue doors lined with refractory insulation, knife edge sealed to square asbestos gasket gives gas tight construction for pressurized firing.
- The CLASSIC III units are offered in a full range of sizes from 60 to 750 hp, fired by a KEWANEE gas, oil or combination gas-oil burner.
- Built-in integral baffle on steam outlet assures dry steam.
- Units furnished with complete line of controls, consisting of, Combination Water Column, Pump Control, Low Water Cut-off, ASME Code Safety Valve(s), Steam Pressure Gauge.
- All CLASSIC III Units are Factory Firetested, firing the unit with the specified fuel and simulating field conditions, adjusting fuel & air ratios plus checking all controls and operating sequence. A detailed report of this test is delivered to the purchaser with each unit. In addition KEWANEE provides Start-Up and 90 days free service by Factory Qualified Organizations. This service includes instruction to the Boiler Operator to obtain trouble free operation.

480 alternate configurations of the basic 3-pass design were Computer evaluated to select optimum arrangements found in the CLASSIC III. With maximum efficiency and minimum pressure drops, this design maintains safe stress levels in critical zones. These Computer results have been completely Laboratory strain gauge tested in Kewanee, and fully performance tested in the field.

RATINGS															
Unit Number		60	70	80	100	125	150	200	250	300	350	400	500	600	750
Rating - Horsepower		60	70	80	100	125	150	200	250	300	350	400	500	600	750
MBh		2009	2343	2678	3348	4184	5021	6695	8369	10043	11716	13390	16738	20085	25106
Steam per Hour - 212°F	lbs.	2070	2415	2760	3450	4313	5175	6900	8625	10350	12075	13800	17250	20700	25875
Steam Gross Output	sq. ft.	8370	9765	11160	13950	17438	20975	27895	34895	41845	48820	55795	69750	83625	104610
Steam - Net (MCA)	sq. ft.	6695	7811	8927	11158	13948	16738	22317	27896	33475	39054	44633	55792	66950	83688
Firing Rate - Gas (1000 BTU/cu. ft.)	MBh	2511	2929	3348	4185	5231	6278	8370	10463	12554	14646	16740	20925	25110	31383
Oil (140,000 BTU)	gph.	17.9	20.9	23.9	29.9	37.4	44.8	59.8	74.7	89.7	104.6	119.6	149.5	179.5	224.2
Oil (150,000 BTU)	gph.	—	—	—	27.9	34.9	41.9	55.8	69.8	83.7	97.6	111.6	139.5	167.5	209.2
Heating Surface - ASME	sq. ft.	300	350	400	500	625	750	1000	1250	1500	1750	2000	2500	3000	3750
Safety Valve Capacity	lbs.	2400	2800	3200	4000	5000	6000	8000	10000	12000	14000	16000	20000	24000	30000
DATA															
Unit Number		60	70	80	100	125	150	200	250	300	350	400	500	600	750
Insulation Thickness	in.	1½	1½	1½	1½	1½	1½	1½	2	2	2	2	2	2	2
Minimum Stack Diameter	in.	12	12	12	12	14	14	16	20	20	20	24	24	27	30
Steam Space	cu. ft.	6.5	7.5	8.4	9.6	11.8	16.4	21.5	34.8	43.1	49.9	57.7	77.1	87.0	107.6
Disengaging area	sq. ft.	17.6	20.1	22.8	23.9	29.5	33.5	43.9	53.7	60.1	69.5	65.2	83.0	91.1	112.7
Water Content (full)	gals.	378	437	499	591	736	875	1161	1474	1987	2302	2329	3004	3526	4394
(to normal waterline)	gals.	330	381	436	519	647	752	1000	1214	1664	1929	1897	2427	2875	3589
Approx. weight (full)	lbs.	8855	9844	11064	13131	15834	18398	23783	28991	36771	42798	45525	56952	67507	83546
Approx. Dry weight	lbs.	5700	6200	6900	8200	9700	11100	14100	16700	20200	23600	26100	31900	38100	46900

DIMENSIONS

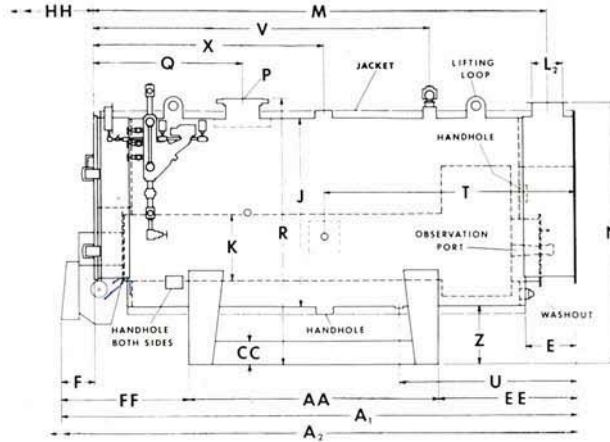
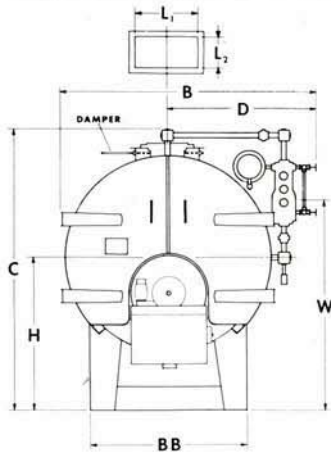

60 H.P. thru 250 H.P.

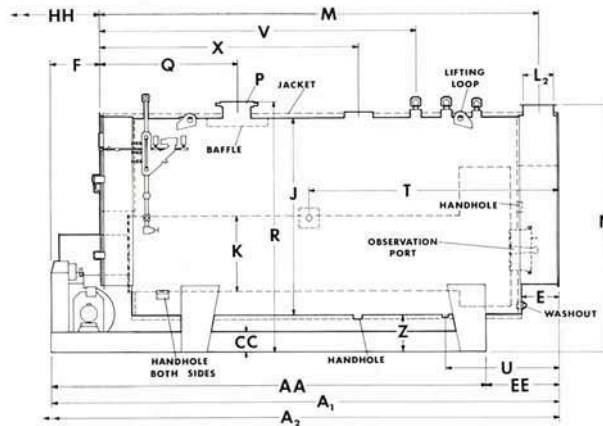
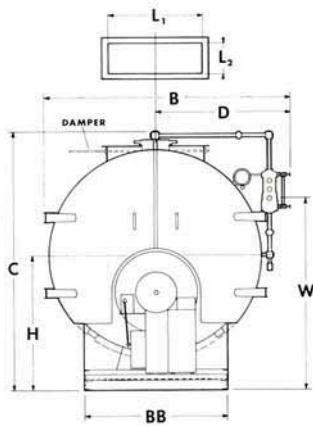

300 H.P. thru 750 H.P.

DIMENSIONS (inches)

Unit Number	60	70	80	100	125	150	200	250	300	350	400	500	600	750
A ₁ - Overall length	122½	134½	146	145	167	165½	201	208	200	223½	205	237	250½	287½
A ₂ - Overall length including Tube Removal	171	195	217½	207½	251	249	319½	328	323	370	333	370	389	471
B - Overall width	65	65	65	71½	71½	77½	84	84	96½	96½	106	112	118	118
C - Overall height	72½	72½	72½	81	81	88	88	95½	107½	107½	116	133	148	151
D - Boiler centerline to greatest width	37½	37½	37½	40½	40½	44	44	47	53	53	60	62½	65½	65½
E - Rear smokebox to shell	12	12	12	12	12	12	12	14	14	14	14	16	16	16
F - Burner to front of boiler	22	22	22	26	26	26	26	26	21½	21½	21½	31½	31	28
H - Boiler centerline height	36½	36½	36½	42½	42½	45½	45½	48½	54½	54½	57½	60½	68½	68½
J - Shell diameter	48	48	48	54	54	60	60	66	78	78	84	90	96	96
K - Furnace diameter	17	17	17	20	20	23	23	25	30	30	34	34	37	37
L ₁ - Smoke outlet length	16	16	16	19	19	24	24	30	38	38	38	38	48	60
L ₂ - Smoke outlet width	8	8	8	9	9	10	10	12	12	12	12	14	14	14
M - Smoke outlet centerline	94½	106	118	112½	134½	132½	168	174	173½	197	178½	197½	208	251
N - Smoke outlet height	65	65	65	74	74	80	80	86	98	98	104	110	121	121
P - Supply Size - 300 lb. ANSI flange	4	4	4	4	4	4	6	6	6	8	8	8	10	10
Q - Supply centerline	38½	38½	38½	38½	38½	38½	38½	38	54	54	54	54½	81½	81½
R - Supply height	66	66	66	75	75	81	81	86	99½	100	106	112	124	124
T - Feedwater centerline - each side	50	57½	63½	47	69	64½	100	107	98½	110	81½	118½	111	143
Feedwater size*	1	1	1¼	1¼	1¼	1¼	1½	1½	1½	2	2½	2½	2½	2½
U - Blow off centerline	42	42	42	42	42	42	42	49	44	49	54	56	66	61
Blow off size	1½	1½	1½	1½	1½	1½	2	2	2	2	2½	2½	2½	2½
V - Safety valve centerline	64	76	87½	82½	90½	91	126½	120	136½	160	141½	123½	125½	178½
W - Normal waterline	55	55	55	62½	62½	67	67	70	81	81	85	89½	100	100
X - Manhole centerline	—	—	—	68½	68½	62½	62½	68	102	112	104	87	105½	116½
Handhole centerline	50	54	59½	—	—	—	—	—	—	—	—	—	—	—
Z - Base height - floor to boiler	12	12	12	15	15	15	15	15	15	15	15	15	20	20
AA - Base length	50	60	70	60	80	80	120	120	172	192	172	204	210	254
BB - Base width	40	40	40	42	42	46	46	50	58	58	64	64	69	69
CC - Base height	6	6	6	6	6	8	8	8	8	8	8	10	10	10
EE - Base to rear of boiler	21	23	24½	29½	31½	30	25½	32½	28	31½	33	33	40½	33½
FF - Base to front of burner	51½	51½	51½	55½	55½	55½	55½	55½	—	—	—	—	—	—
HH - Tube removal space	71	83	94	89	110½	110	145	147	143	166	147	164	169	212

* Threaded opening.